

ELECTROMECHANICAL LOCK

Promix-SM308

OPERATING MANUAL

Technical description. Installation manual. Certificate.

ПШБА.304268.305 РЭ

PATENT FOR INVENTION

No.2666310

1. PURPOSE

Electromechanical locks series Promix-SM308 with a hook-shaped locking mechanism (below called the locks) are intended for restriction of access to cells of luggage lockers (post offices), drawers for storage of documentation, lockers and cabins in locker rooms of fitness clubs, swimming pools, schools, factories; the locks can be opened remotely.

2. LABELING

The label stuck to the lock body contains the following information:

1. Lock model.
2. Patent number.
3. Nominal supply voltage.
4. Nominal consumed current.
5. Date of manufacture and QCD mark
6. Identification number.
7. Manufacturer's website.

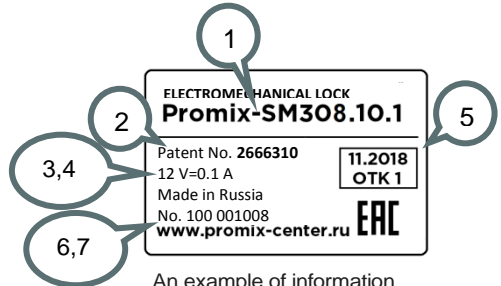

An example of information layout on the label.

Promix-SM308.1 X.1

Availability of built-in sensors:

1 – door position sensor

Supply voltage:

0 - 12V. 1 -24V

Version:

1 - normally closed

For the list of lock modifications that can be ordered, see 5.2.

The color of the product is shown on the sticker stuck to the box, after the product name. Series colors: **Silver**, **White**, **Brown**, **Black**. Other colors are provided optionally.

3. SET OF DELIVERY

- | | |
|-------------------------------------|--------|
| 1 – Lock | 1 pc. |
| 2 – Latch | 1 pc. |
| 3 – Self-tapping screw 3.5x15 (cup) | 5 pcs. |
| 4 – Operating manual | 1 pc. |

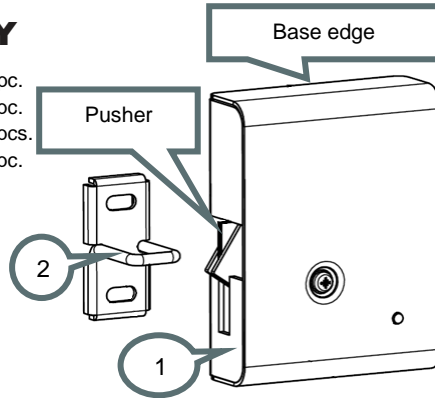

Check completeness of the lock set when buying! After buying, the manufacturer will not accept claims related to incomplete set.

4. DESIGN AND PRINCIPLE OF OPERATION

The lock Promix-SM308 is produced in a normally closed version, i.e., it is in the closed state when de-energized and opens as supply voltage is applied.

The lock is mounted on inner surfaces of the locker transversely to the door and is operable in both vertical and horizontal positions. The mating part (latch) is mounted on the door.

As the door is closed, the latch is inserted in the lock and becomes blocked therein. As supply voltage is applied, the lock deblocks the latch and pushes it with a built-in pusher, which allows to eliminate mounting of a handle on the door.

The spring-loaded pusher of the lock is connected to the door position sensor. The operating principle of the sensor is described in 6.3.

5. TECHNICAL DATA

5.1 OPERATING CONDITIONS

The lock operation environment must be explosion-safe, free of current-conducting dust or gases that cause metal corrosion and destroying insulation of current conductors and electric elements, free of current-carrying dust or water vapor, and preventing ingress of water, steam, fuel and lubricants.

Climatic conditions of operation – Y3.1 as per GOST 15150-69 with extended temperature range:

- ambient temperature: from -30 to +50 °C;
- Relative air humidity: not higher than 98% at 25°C or lower temperatures without moisture condensation and hoar-frost formation;
- installation indoors or outdoors excluding ingress of moisture, dust, dirt, etc. inside the lock.

5.2 TECHNICAL DATA

Modification	Promix-SM308.10.1	Promix-SM308.11.1*
Version	normally closed	
DC supply voltage U, V	12±2	24±2
Current consumed, A	0.4 (at 12V)	0.27 (at 24V)
Supply pulse duration (not more than), s	1-10	
Minimum pause between pulses, s	15	20
Built-in sensors	door position sensor	
Maximum switch current of the sensor (DC), A:	0.2	
Maximum switch voltage of the sensor (DC), V:	24	
Sensor output signal type	“dry contact”	
Lock weight (not more than), kg	0.27	
Holding force (not less than), kg	250	
Initial latch pushing out force (not less than), kg	1.2	

* - Manufactured against order

Lock and latch overall and mounting dimensions.

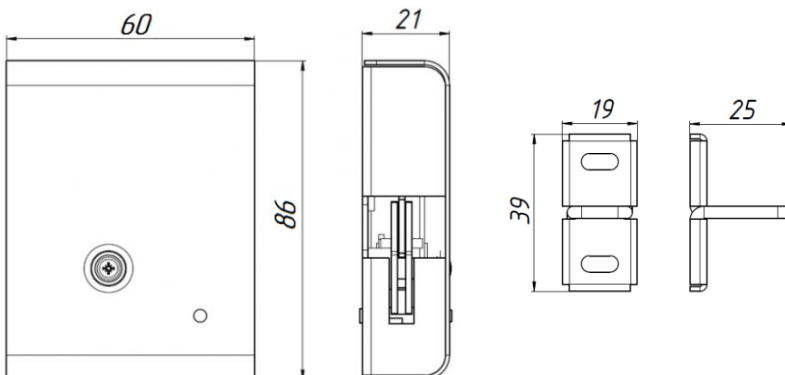

6. INSTALLATION AND CONNECTION

6.1 LOCK AND LATCH MOUNTING

1. Screw out the screw on the front surface of the lock and remove the cover.
2. Mount the lock on a wall, at a distance of 15mm from the locker wall edge.

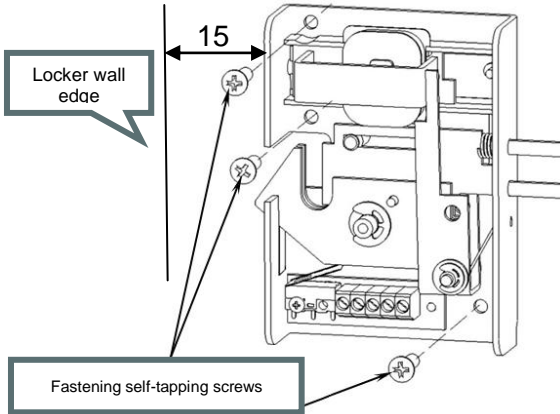

3. Connect the lock to the power supply (see 6.3).
4. Insert the latch into the lock.
5. Test operability of the lock – as voltage is applied, the lock must push out the latch.
6. Fasten the latch to the door at a distance of 20 ± 3 mm from the base edge of the lock (see Fig. below).

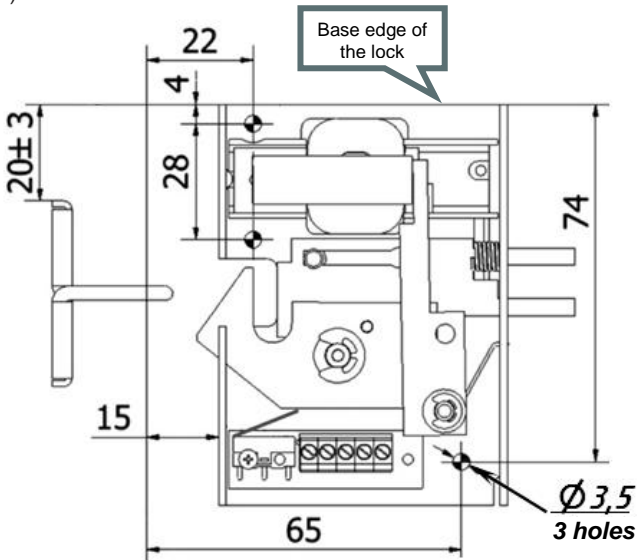

7. Test operability in door closing.

6.2 EMERGENCY OPENING OF THE LOCK

For emergency opening of the lock, insert a wire (e.g., a paper clip) and, having caught the part “lever” (see the Figure below), move it until the lock operates.

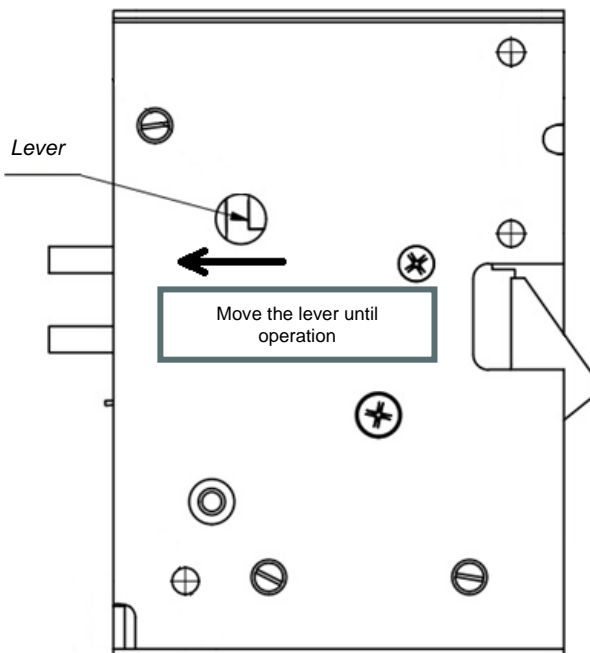

6.3 CONNECTING PROCEDURE

The lock operation is controlled by means of energizing and de-energizing. For this purpose, a controller (control board) or a switch (button) is generally used. The controller is mounted in accordance with its certificate.

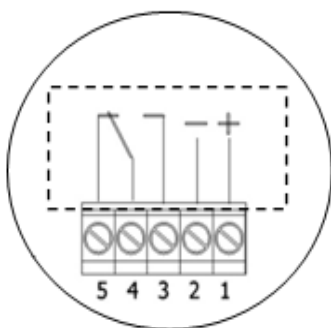

Purpose of terminals:

- 1-2 Lock energizing.
- 3 Normally open contact of the sensor.
- 4 Common contact of the sensor.
- 5 Normally closed contact of the sensor.

Connect the lock power wires adhering to the following polarity:

- Terminal 1 – positive pole of the power supply;**
- Terminal 2 – negative pole of the power supply;**

Application of voltage of reverse polarity does not provide the lock operability but does cause its failure.

Promix-SM308

When the pusher is embedded in the lock (the door is closed), the output contacts 3-4 of the sensor are closed 3-4 (5-4 are open); when the pusher is shifted out of the lock (the door is open), the output contacts 3-4 of the sensor are open (5-4 are closed).

See operating voltage range in 5.2. Avoid supply of overvoltage.

Example of the lock connection to the remote control system Promix-RDS.

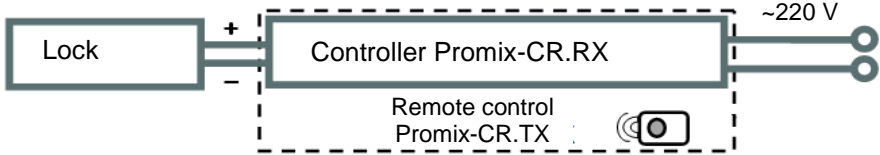

Provide a reliable electriccontact. To prevent short-circuit, insulate places of connection.

7. SPECIAL ASPECTS OF INSTALLATION AND OPERATION

- 1) The possibility of using the lock and the place of installation (outdoors or indoors) are determined by the **installation organization** on the basis of the design features and the lock operating principle, method of installation, room criticality level, the purpose of the access restriction regime and other factors (the presence of security providers, video surveillance, etc.).
- 2) To prevent deformations of the door due to attempts to open the door with the lock closed, it is recommended to mount the lock in the area of the door handle.
- 3) It is recommended to install the lock together with a door closer – this reduces impact load on the lock and extends its service life.

8. TROUBLE-SHOOTING

Troubles and problems	Remedies
The lock does not fix the latch (the door is not fixed in the closed state).	Check the absence of supply voltage. Adjust the latch position (see 6.1) so that the latch, with the door closed, enters the lock slot until the catch hook operates.
The latch does not enter the lock slot, or enters with friction.	Restore position of the door that changed in the course of operation. If restoration is impossible, adjust the latch (see 6.1)

9. MAINTENANCE

Maintenance of the lock is performed at least once every two months and includes:

- Visual inspection of the lock to check reliability of fastening. If necessary, tighten fasteners of the lock and the latch.
- Checking the proper position of the latch. (see section 8).

The lock does not need lubrication!

10. STORAGE AND TRANSPORTATION

Prior to putting into operation, the locks must be stored in the manufacturer's packing, in rooms with an ambient temperature of -30 to +50 °C and a relative humidity not higher than 98% at 25° C in compliance with storage conditions as per GOST 15150-69.

Locks transportation conditions must comply with group C as per GOST 23216-78 in terms of exposure to mechanical factors, and Ж2 as per GOST 15150-69 in terms of exposure to climatic factors.

11. SAFETY REQUIREMENTS

The design of the locks ensures safety of personnel involved in mounting and maintenance.

Due to low DC supply voltage, the products correspond to class III as per ГОСТ 12.2.007.0-75 and are electrically safe.

Fire safety of the locks is ensured by use of non-combustible or hardly combustible materials, and low supply voltage.

12. DISPOSAL

The product is not hazardous for human life and health or for the environment; disposal after its service life is performed without taking any special measures for environment protection.

13. WARRANTY LIABILITIES

The manufacturer, ETC PROMIX LLC, warrants conformity of Promix-SM308 locks to requirements of current Technical Specifications provided that transportation, storage, installation and operation rules established in this Manual are followed.

The warranted operation period is 12 months from the date of sale but not longer than 18 months from the day of acceptance by the manufacturer's QCD.

Within the period of warranty, ETC PROMIX LLC undertakes to repair defective products free of charge. Expenses for transporting the product to the place of repair and back will be borne by the Buyer.

Warranty liabilities do not cover any defects and damages caused by:

- Improper maintenance by the Buyer;
- Use of the product under conditions that do not comply with the operation requirements;
- Mechanical damages or disassembly of the products by the Buyer;
- Non-observance of the transportation and storage rules.

Faulty products are accepted for repair only together with the latch, on the obligatory condition that factory labels are retained on the product body.

On expiration of the warranty service period, the manufacturer provides after-warranty service on a contractual basis.

To improve product quality the manufacturing plant reserves the right to make modifications to the product design without prior notice.

14. ACCEPTANCE AND PACKING CERTIFICATE

Electromechanical lock Promix-SM308 in quantity of ____ pieces (1 pc. by default) bearing the manufacturing date and QCD mark on the body, was manufactured and accepted in compliance with Specifications ПШБА.304268.003 ТУ, obligatory requirements of state standards and current technical documentation, recognized as fit for operation and packed by ETC PROMIX LLC.

PROMIX Engineering and Technical Center LLC
Russia, 214030, Smolensk, Krasninskoye sh., 35, lit. A
Phone: (4812) 619-330
www.promix-center.ru
vk.com/promixcenter
facebook.com/promixcenter
mail@promix-center.ru

EAC

