

## OPERATING MANUAL

Technical description. Installation manual. Certificate.

## PATENT FOR INVENTION

No.2615712

## 1. PURPOSE

The electromechanical locks series Promix-SM306 with a hook-shaped locking mechanism (below called the locks) are intended to be use as actuating devices in an access control system (ACS) for locking doors of offices and administrative rooms with a door frame ledge wider than 25 mm.

## 2. LABELING

The label stuck to the lock body contains the following information:

1. Lock model.
2. Patent number.
3. Nominal supply voltage.
4. Nominal consumed current.
5. Date of manufacture and QCD mark
6. Identification number.
7. Manufacturer's website.



An example of information layout on the label.

### Promix-SM306.X0

Supply voltage:

0 - 12V.

Version:

0 - normally opened, 1 - normally closed

For the list of lock modifications that can be ordered, see 5.2.

The color of the product is shown on the sticker stuck to the box, after the product name. Series colors: **Silver, White, Brown**. Other colors are provided optionally.

### 3. SET OF DELIVERY

- |   |        |
|---|--------|
| 1 – Lock  | 1 pc.  |
| 2 – Latch   | 1 pc.  |
| 3 – Adjustment plate<br>(in the as-delivered condition,<br>screwed to the lock with screws 4) | 1 pc.  |
| 4 – Screw M4x16 (countersunk)   | 4 pcs. |
| 5 – Screw M6x25 (countersunk)   | 2 pcs. |
| 6 – Self-tapping screw 3.5x30   | 4 pcs. |
| 7 – Barrel nut  | 2 pcs. |
| 8 – Self-tapping screw 5.5x32   | 2 pcs. |
| 9 – Plug  | 2 pcs. |
| 10 – Angular template   | 1 pc.  |
| 11 – Operating manual   | 1 pc.  |

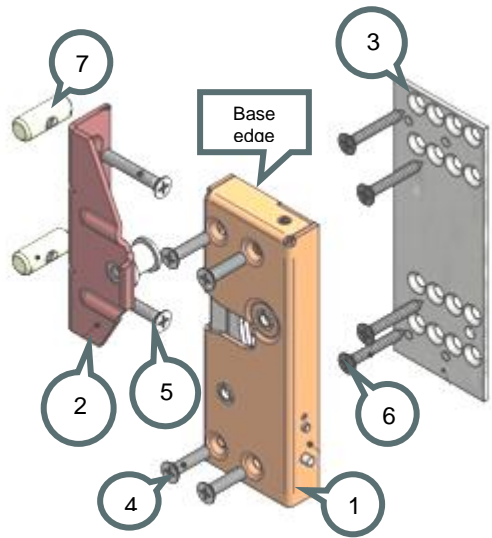

**Check completeness of the lock set when buying! After buying, the manufacturer will not accept claims related to incomplete set.**

### 4. DESIGN AND PRINCIPLE OF OPERATION

The locks are produced in two versions: normally opened (NO), and normally closed (NC). NO lock is in the open state when de-energized and in the closed state when voltage is supplied. NC lock is in the closed state when no voltage is supplied, and in the open state when the lock is energized. For opening the lock, it is necessary to de-energize a normally open lock or to supply voltage to a normally closed lock.

The lock is mounted at any place at the door ledge, and the latch is mounted on the door. The possibility of mechanical deblocking is provided for emergency opening of the lock.

A protective shutter for preventing unauthorized opening of the lock is provided in the lock design (optional).

Adjustment holes on the adjustment plate serve for correcting the latch roller position relative to the snap channel in the vertical direction (e.g., in case of the door sagging) and in the horizontal direction.

As the door is closed, the latch enters the slot in the lock and, overcoming the catch hook force, is fixed transferring the catch hook from "open" position to "closed" position. As supply voltage is applied (or, for a normally closed version, as the lock is de-energized), the catch hook is blocked in the "closed" position and locks the latch.

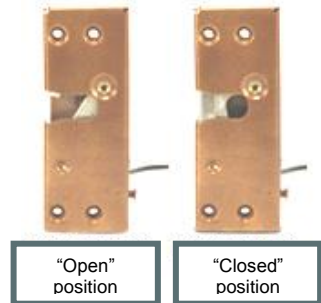

## 5. TECHNICAL DATA

### 5.1 OPERATING CONDITIONS

The lock operation environment must be explosion-safe, free of current-conducting dust or gases that cause metal corrosion and destroying insulation of current conductors and electric elements, free of current-carrying dust or water vapor, and preventing ingress of water, steam, fuel and lubricants.

Climatic conditions of operation – Y3.1 as per GOST 15150-69 with extended temperature range:

- ambient temperature: from -30 to +50 °C;
- Relative air humidity: not higher than 98% at 25°C or lower temperatures without moisture condensation and hoar-frost formation;
- installation indoors or outdoors excluding ingress of moisture, dust, dirt, etc. inside the lock.

**NC locks are not intended for outdoor installation. NO lock can be mounted outdoors on condition that it is energized for most time.**

### 5.2 TECHNICAL DATA

Modification	Promix-SM306.00	Promix-SM306.10
Version	normally opened	normally closed
DC supply voltage U, V	12±2	
Current consumed, A	0.1 (at 12V)	
Supply pulse duration (not more than), s	not rated.	
Minimum pause between pulses, s	not rated.	
Lock weight (not more than), kg	0.3	
Holding force (not less than), kg	300	
Power wire length, m	0.3	
Allowable clearance between the door frame and the door, mm	10-15	

**Lock and latch overall and mounting dimensions.**

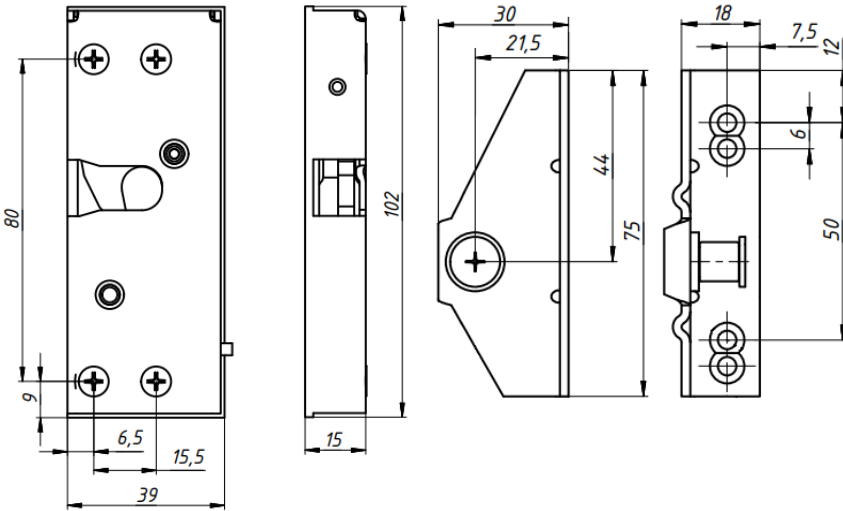

**6. INSTALLATION AND CONNECTION**

**6.1 LOCK AND LATCH MOUNTING**

1. Apply the lock1 with inserted latch 2 and fitted over angular template 10 to the planned mounting place so that:
  - a) The required clearances are ensured between the latch and the lock, the clearances being provided by the angular template10 (see Fig. 1)
  - b) The latch roller is at the center of the lock slot; to provide this, the base edges of the latch and the lock must be at the same level (see Fig. b in section 3).

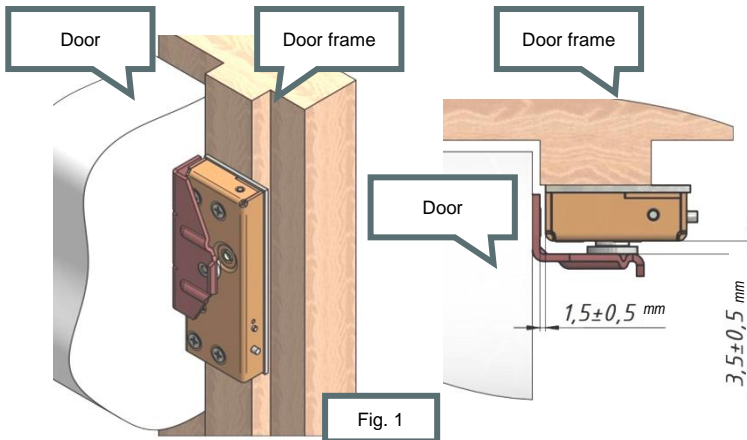

2. Mark positions of the latch and the lock.
3. Apply the adjustment plate 3 to earlier made marks and mark optimum places for fastening

and the opening for the lock power wire.

4. Drill holes  $\varnothing 2\text{mm}$  ( $\varnothing 5\text{mm}$  for the power wire) and fix the plate with self-tapping screws **6**.
5. Pull the latch out of the lock. Mount the lock **1** on the adjustment plate **3** using screws **4**.
6. Remove the angular template **10** from the latch **2**, apply the latch to the door according to the marks made earlier, and mark the latch fastening places.
7. Drill two holes  $\varnothing 7\text{mm}$  to a depth of at least 30mm.
8. Mark on the door end holes for barrel nuts **7** at the same level with the holes  $\varnothing 7\text{mm}$  (see Fig.2).

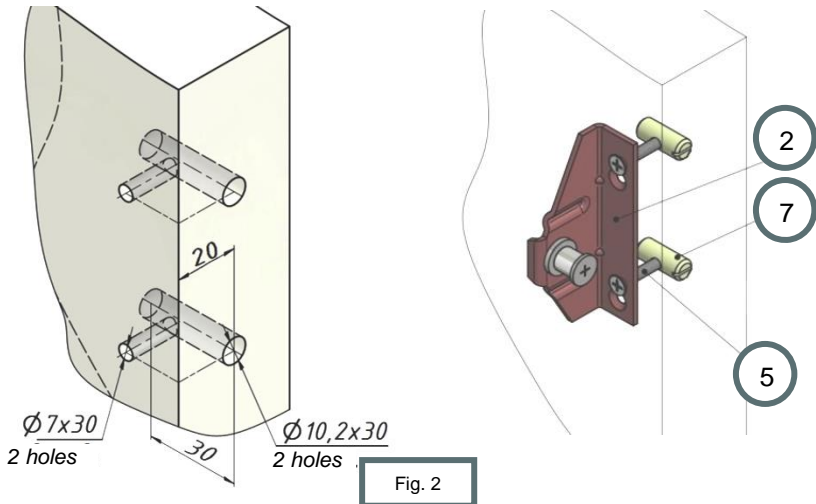

9. Drill two holes  $\varnothing 10.2\text{mm}$  to a depth of at least 30mm at marked places.
10. Mount the latch **2** on the door using screws **5** and barrel nuts **7** (see Fig.2).
11. Close the holes with barrel nuts **7** with plugs **9**.
12. Test operability of the installed lock together with the latch.

The latch **2** can also be fastened to the door by means of self-tapping screws **8**; to do this, drill for them two holes  $\varnothing 4\text{-}5\text{mm}$  to a depth of at least 30mm (instead of items 6.1.7-6.1.11).

A row of adjustment holes on the adjustment plate **3** serves for correcting the latch roller position relative to the lock channel in the vertical direction (e.g., in case of the door sagging) and in the horizontal direction.

## 6.2 CONNECTING PROCEDURE

The lock operation is controlled by means of energizing and de-energizing. For this purpose, a controller (control board) or a switch (button) is generally used. The controller is mounted in accordance with its certificate.

Connect the lock power wires adhering to the following polarity:

**Red (black with a red stripe) – positive pole of the power supply;**

**Black – negative pole of the power supply;**

Application of voltage of reverse polarity does not provide the lock operability but does cause its failure.

See operating voltage range in 5.2. Avoid supply of overvoltage.

Example of the lock connection to the remote control system Promix-RDS.

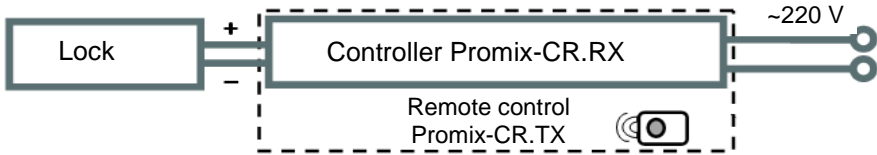

Provide a reliable electric contact. To prevent short-circuit, insulate places of connection.

## 7. SPECIAL ASPECTS OF INSTALLATION AND OPERATION

- 1) The possibility of using of the locks for restriction of access to the premises and the place of installation (outdoors or indoors) are determined by the **installation organization** on the basis of the design features and the mounting method, room criticality level, the purpose of the access restriction regime and other factors (the presence of security providers, video surveillance, etc.).
- 2) To prevent deformations of the door due to attempts to open the door with the lock closed, it is recommended to mount the lock in the area of the door handle.
- 3) It is recommended to install the lock together with a door closer – this reduces impact load on the lock and extends its service life.
- 4) Operation of an installed NC lock should be tested only if the supply voltage can be applied thereto.

## 8. TROUBLE-SHOOTING

Troubles and problems	Remedies
The lock does not fix the latch roller (the door is not fixed in the closed state).	Check polarity and conformity of the lock supply voltage to the required value. Adjust the latch (see 6.1) so that, with the door closed, the roller enters the snap slot before operation of the catch hook.
The door is not closed completely since the latch does not enter the snap.	Perhaps the catch hook was manually transferred to the "closed" position (see Fig. in section 4). Deblock the catch hook and transfer it to the "open" position manually.

<p>The latch roller does not enter the snap slot, or enters with friction.</p>	<p>Restore position of the door that changed in the course of operation. If restoration is impossible, adjust the latch (see 6.1)</p>
<p>The door is not opened when transferred to the "open" state. To open the door, one has to press it more snugly to the door frame.</p>	<p>Remove the causes of the non-tight door bearing against the door frame. Adjust the latch in the horizontal plane.</p>

## 9. MAINTENANCE

Maintenance of the lock is performed at least once every two months and includes:

- Visual inspection of the lock to check reliability of fastening. If necessary, tighten fasteners of the lock and the latch.
- Checking the proper position of the latch. (see section 8).

**The lock does not need lubrication!**

## 10. STORAGE AND TRANSPORTATION

Prior to putting into operation, the locks must be stored in the manufacturer's packing, in rooms with an ambient temperature of -30 to +50 °C and a relative humidity not higher than 98% at 25° C in compliance with storage conditions as per GOST 15150-69.

Locks transportation conditions must comply with group C as per GOST 23216-78 in terms of exposure to mechanical factors, and Ж2 as per GOST 15150-69 in terms of exposure to climatic factors.

## 11. SAFETY REQUIREMENTS

The design of the locks ensures safety of personnel involved in mounting and maintenance.

Due to low DC supply voltage, the products correspond to class III as per GOST 12.2.007.0-75 and are electrically safe.

Fire safety of the locks is ensured by use of non-combustible or hardly combustible materials, and low supply voltage.

## 12. DISPOSAL

The product is not hazardous for human life and health or for the environment; disposal after its service life is performed without taking any special measures for environment protection.

## 13. WARRANTY LIABILITIES

The manufacturer, ETC PROMIX LLC, warrants conformity of Promix-SM306 locks to requirements of current Technical Specifications provided that transportation, storage, installation and operation rules established in this Manual are followed.

**The warranted operation period is 12 months from the date of sale but not longer than 18 months from the day of acceptance by the manufacturer's QCD.**

## Promix-SM306

Within the period of warranty, ETC PROMIX LLC undertakes to repair defective products free of charge. Expenses for transporting the product to the place of repair and back will be borne by the Buyer.

Warranty liabilities do not cover any defects and damages caused by:

- Improper maintenance by the Buyer;
- Use of the product under conditions that do not comply with the operation requirements;
- Mechanical damages or disassembly of the products by the Buyer;
- Non-observance of the transportation and storage rules.

**Faulty products are accepted for repair only together with the latch, on the obligatory condition that factory labels are retained on the product body.**

On expiration of the warranty service period, the manufacturer provides after-warranty service on a contractual basis.

**To improve product quality the manufacturing plant reserves the right to make modifications to the product design without prior notice.**

## **14. ACCEPTANCE AND PACKING CERTIFICATE**

Electromechanical lock Promix-SM306 in quantity of \_\_\_\_ pieces (1 pc. by default) bearing the manufacturing date and QCD mark on the body, was manufactured and accepted in compliance with Specifications, obligatory requirements of state standards and current technical documentation, recognized as fit for operation and packed by ETC PROMIX LLC.

PROMIX Engineering and Production Center LLC  
Russia, 214030, Smolensk, Krasninskoye sh., 35, lit. A  
Phone: (4812) 619-330

[www.promix-center.com](http://www.promix-center.com)  
[facebook.com/promixcenter](https://facebook.com/promixcenter)  
[mail@promix-center.com](mailto:mail@promix-center.com)

